

# HOW TO INSTALL HORIZONTAL ROD RAILING

## TREX® SIGNATURE™ STANDARD

### NOTES:

- » Adjust drill power to lowest setting that will drive screw. **DO NOT OVER TORQUE 316 STAINLESS STEEL STAINLESS FASTENERS.**
- » **NEVER** use impact tools on 316 Stainless Steel Fasteners.
- » Be careful inserting rods through intermediate vertical supports. Lay pieces on a flat, solid surface and insert as straight as possible to prevent scratching.
- » When marking lines on bottom rail, do not make a mark wider than 1" or it will be visible after installation.

### SAFETY

When working on any construction project, you should wear protective clothing and safety equipment. Wear safety glasses, gloves, a dust mask and long sleeves, particularly when cutting in confined spaces. Trex decking and railings are heavier and more flexible than wood. Go to [www.trex.com](http://www.trex.com) for Safety Data Sheets (SDS).

### PARTS

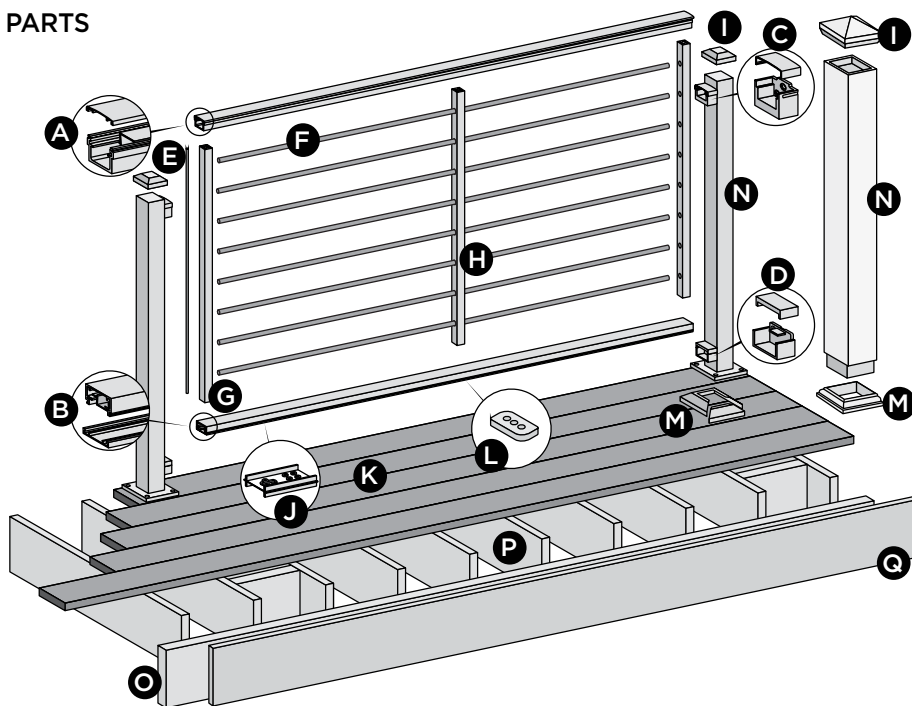

### TOOLS NEEDED

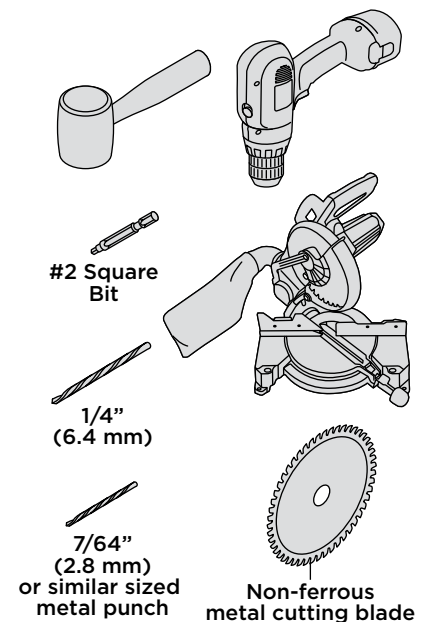

- A. Trex® Signature™ upper rail cover
  - 6' (actual length 73-1/2" [1867 mm])
  - 8' (actual length 97-1/2" [2477 mm])
- B. Trex® Signature™ bottom rail and flat cover
  - 6' Rail (actual length 71-1/2" [181.6 cm])
  - 6' Cover (actual length 70" [177.8 cm])
  - 8' Rail (actual length 95-1/2" [242.6 cm])
  - 8' Cover (actual length 94" [238.8 cm])
- C. Trex® Signature™ upper rail bracket and cover
- D. Trex® Signature™ lower rail bracket and cover
- E. Anti-rattle strip
- F. Rod
- G. End vertical support
- H. Intermediate vertical support\*
- I. Trex® Signature™ post cap or post sleeve cap\*\*
- J. Template
- K. Trex decking
- L. HZ spacer
- M. Trex® Signature™ post skirt or post sleeve skirt\*\*
- N. Trex® Signature™ post\*
  - (2" or 2.5" depending on application)
  - 36" (actual length 37" [94.0 cm])
  - 42" (actual length 43" [109.2 cm])
  - or Trex 4" x 4" post sleeve\*
  - 36" (actual length 39" [99.1 cm])
  - 42" (actual length 45" [114.3 cm])
- O. Code-approved wood rim joist 2" x 8" (5.1 cm x 20.3 cm) or larger
- P. Code-approved wood joist 2" x 8" (5.1 cm x 20.3 cm) or larger
- Q. Trex Fascia
  - \* 1 for 6' span/2 for 8' span
  - \*\* Item not included in Trex® Signature™ Railing kits. Both 4" x 4" (10.2 cm x 10.2 cm) and 6" x 6" (15.2 cm x 15.2 cm) post sleeves are designed to fit over 4" x 4" pressure-treated post.

# HOW TO INSTALL HORIZONTAL ROD RAILING/CONTINUED

## TREX® SIGNATURE™ STANDARD

### NOTES:

» REFER TO TREX® SIGNATURE™ INSTRUCTIONS FOR POST INSTALLATION AND BRACKET LOCATION INSTALLATION.

1. Prepare a solid work surface area (plywood, deck surface, etc.).

### How to Measure Bottom and Top Railings (When Required)

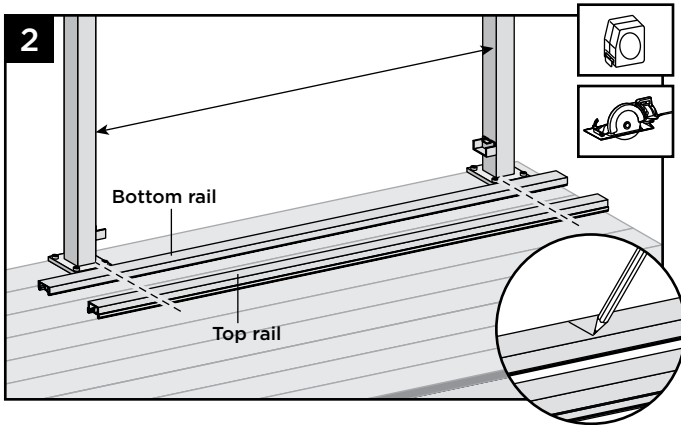

2. Position bottom and top rails between posts and align with bottom bracket. Mark bottom rail and top rail at each end.

### Cutting Railings and Covers

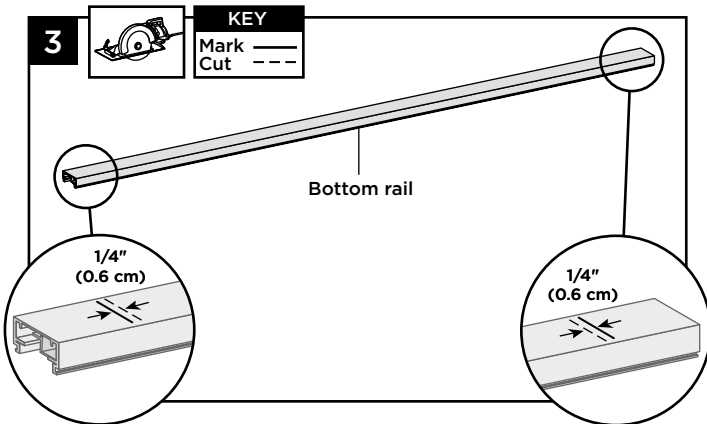

3. Cut each end of bottom and top rail 1/4" (0.6 cm) shorter than mark on each end to allow for fit into bottom rail brackets.

If installing crossover railing, add 3/4" to each side of top rail.

If using swivel brackets, measure distance between brackets and cut railings to this distance.

4. Mark and cut bottom rail cover 1-1/2" (3.8 cm) shorter than bottom rail.

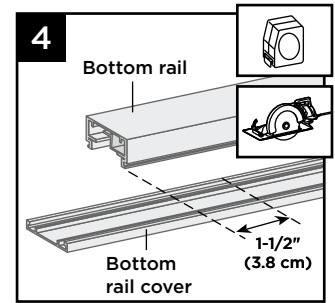

5. Mark and cut top rail cover same length as top rail for all top rail configurations.

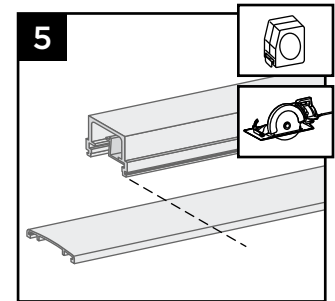

### Locating Vertical Holes on Bottom and Top Rails

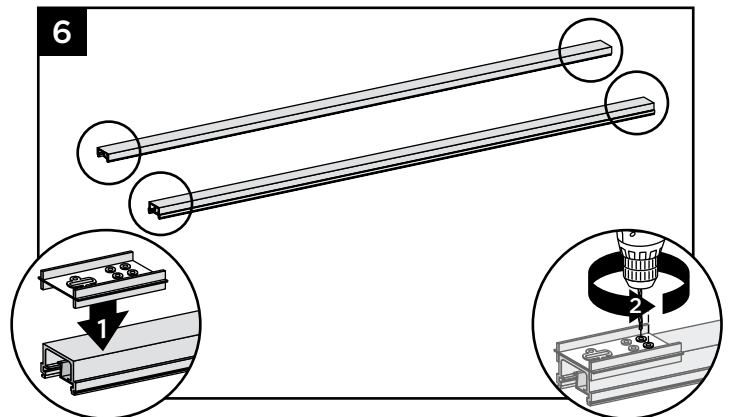

6. Place HZ template at end of top and bottom rails. Pre-drill pilot holes (using a 7/64" bit or small punch) at locations.

### NOTES:

- » Template is labeled for the type of bracket used.
- » Pilot holes will be drilled out larger in a later step.
- » For Compound Swivel Brackets, set the rail in the bracket and mark 3.75" from the post.

## 6' Rail Spans or Shorter

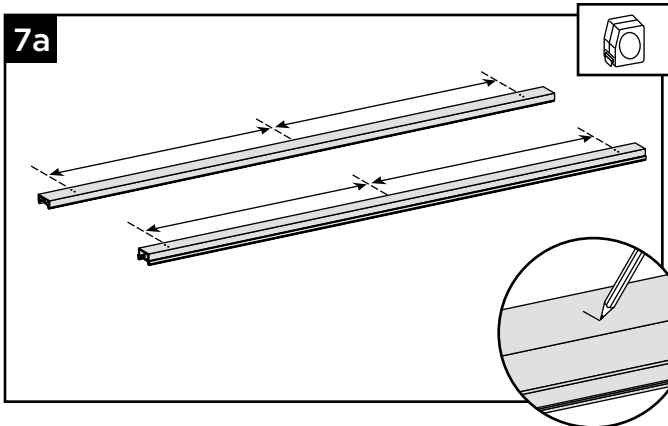

7a. Measure the distance between the vertical end holes on **both top and bottom rails**. Mark the center.

**IMPORTANT: DO NOT** mark the line across the entire width of the bottom rail, as it will be visible after install. Maximum recommended line width is 1".

## Over 6' Rail Spans

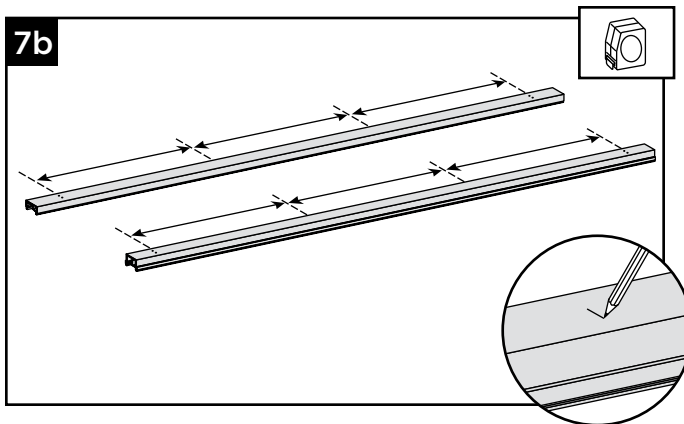

7b. Measure the distance between the vertical end holes on **both top and bottom rails**. Divide the distance into thirds and make two marks on top and bottom rails.

**NOTE:** Maximum unsupported rod span is 32.25".

## Locating and Drilling Midspan Holes

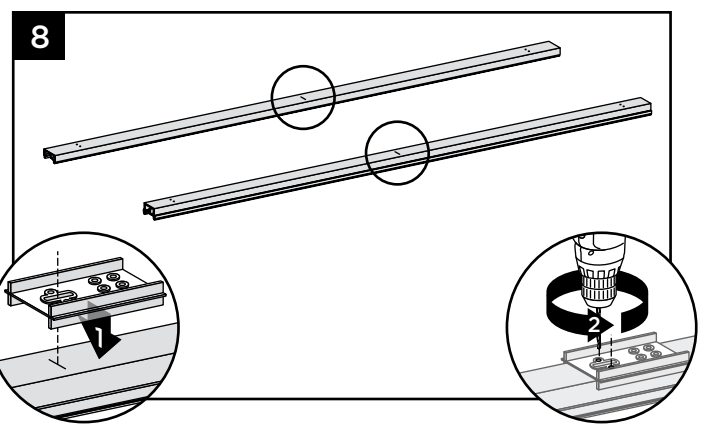

8. Using the slot on the HZ template, locate marked line and drill two 7/64" pilot holes (or mark with a punch).

**NOTE:** Pilot holes will be drilled out larger in next step.

9. Using pilot holes (or marks), drill 1/4" holes for all vertical supports in both top and bottom rails.

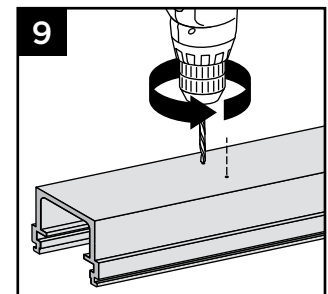

**NOTE:** Clean any burrs from edges of holes to ensure good fit on both sides.

## Cutting Rods to Length (When Required)

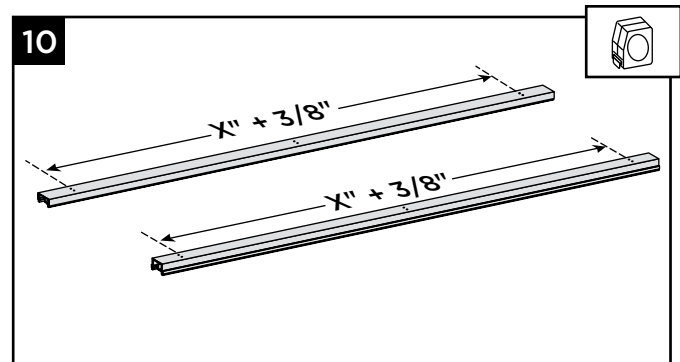

10. Measure the distance between the end (outer) holes (X") on top or bottom rail and add 3/8" to this measurement.

**NOTE:** If installed at exact spans, rods do not have to be cut.

# HOW TO INSTALL HORIZONTAL ROD RAILING/CONTINUED

## TREX<sup>®</sup> SIGNATURE<sup>™</sup> STANDARD

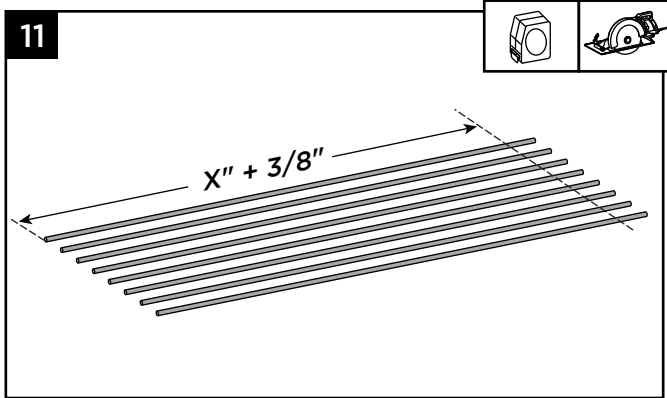

11. Cut rods to the length measured in previous step.

### Vertical and Rod Assembly

12. Insert anti-rattle strips into the vertical supports.

*NOTE: There are two anti-rattle strips for each support and can only be inserted in one side.*

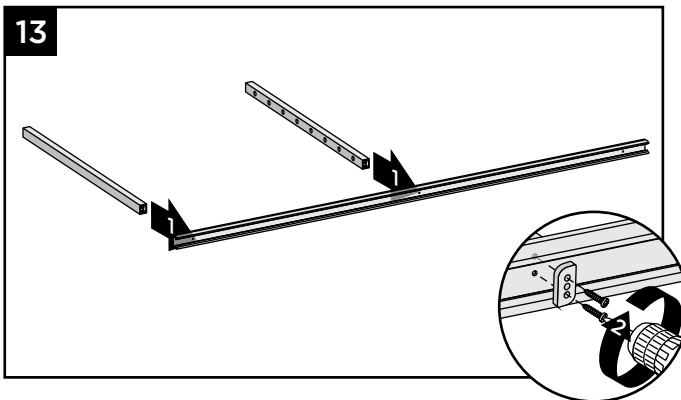
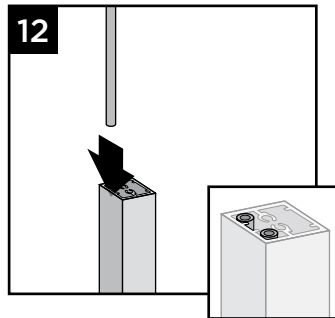

13. Attach **one** end vertical and **all** intermediate verticals to bottom rail using HZ spacer and screws provided.

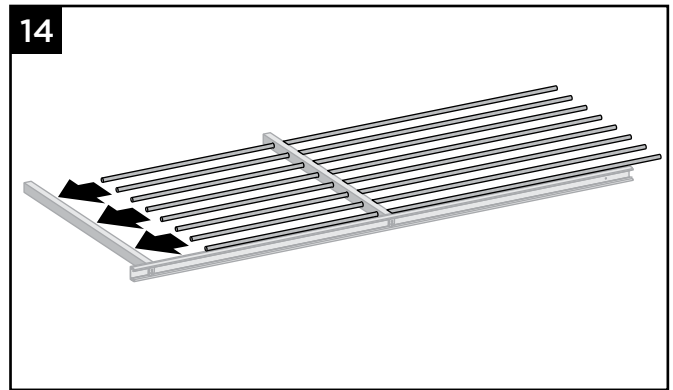

14. Slide all rods through intermediate supports and into end vertical support.

*NOTE: When inserting rods through intermediate supports, keep rods straight to avoid scratching.*

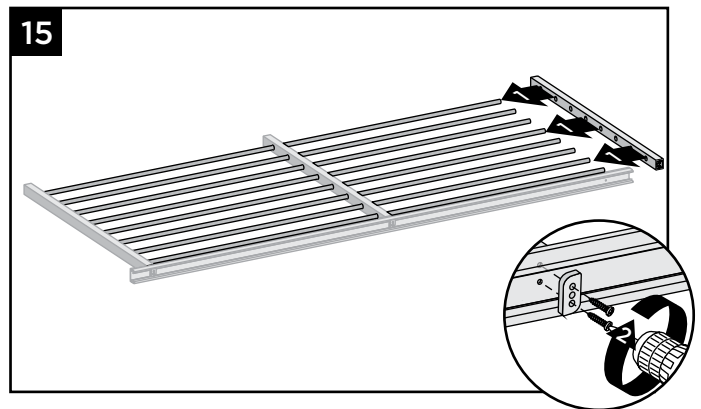

15. Slide end vertical onto rods and attach to bottom rail using HZ spacer and screws provided.

### Installing Top and Bottom Rails

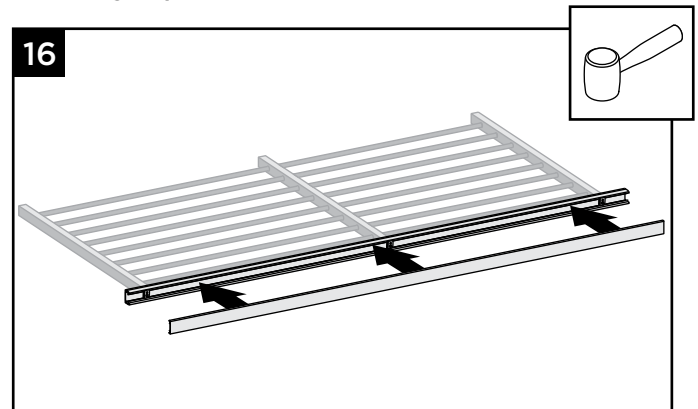

16. Using a mallet, install bottom rail cover onto bottom rail.

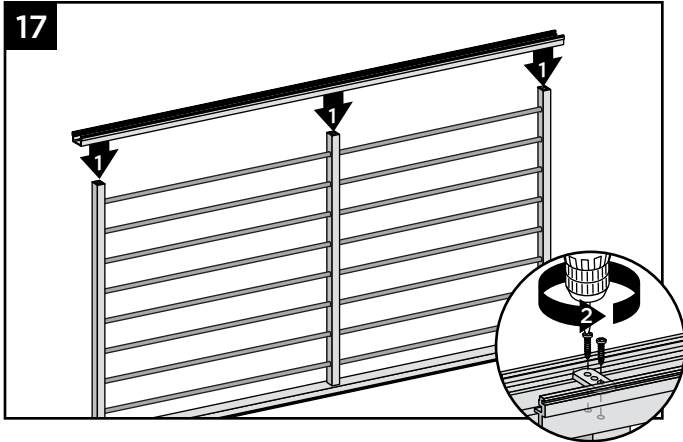

17. Install top rail to all vertical and end supports using HZ spacer and screws provided.

**NOTE:** It's easiest to place the bottom rail on the ground and install the top rail from above.

### Final Installation

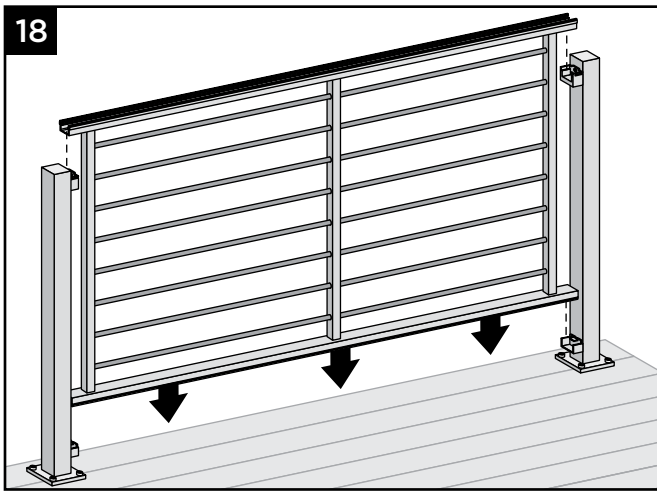

18. Drop assembled rod rail panel into brackets.

19. Attach bottom rail to bottom brackets by using one self-tapping screw (provided) for each bracket.

**NOTE:** Pre-drilling is required (7/64" [0.28 cm] drill bit) for attachment of railing to bracket.

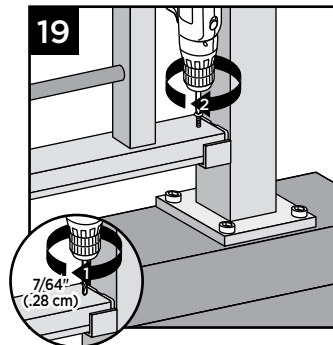

20. Attach top rail to top brackets by using two self-tapping screws (provided) for each bracket.

**NOTE:** Pre-drilling is required (7/64" [0.28 cm] drill bit) for attachment of railing to bracket.

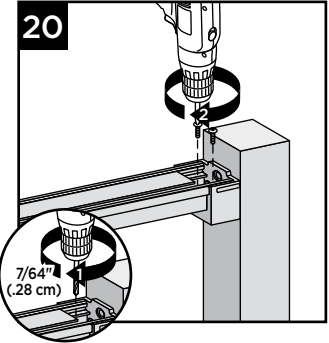

### Attachment of Bracket Covers, Skirts, and Caps

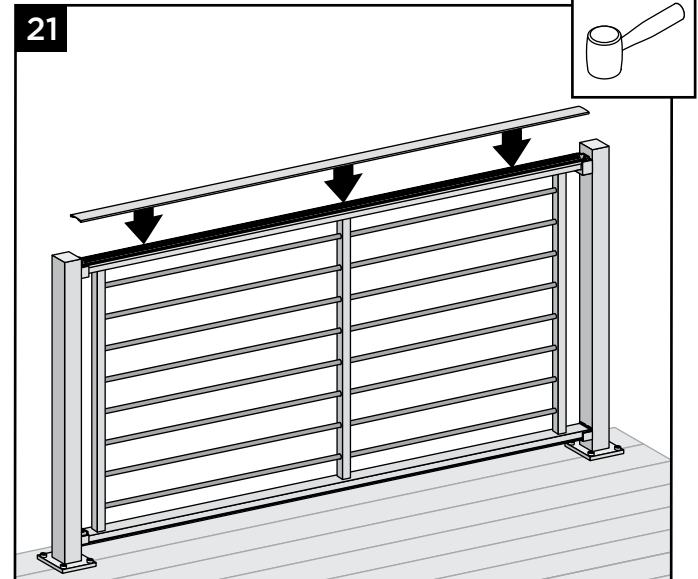

21. Using a mallet, install top rail cover.

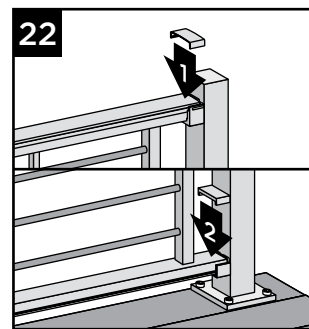

22. Attach corresponding bracket covers over opening in top and bottom rails.

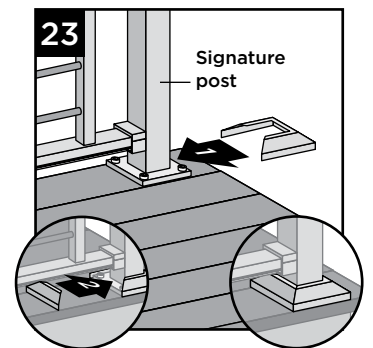

23. Attach provided post skirt to bottom of posts when using Trex® Signature™ posts.

# HOW TO INSTALL HORIZONTAL ROD RAILING/CONTINUED TREX® SIGNATURE™ STANDARD

24. Attach post caps to Trex® Signature™ posts. (Use of **rubber mallet** may be required for secure attachment.)

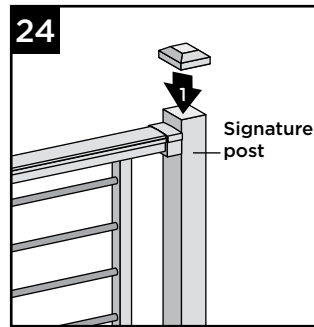

25. Attach post caps to post sleeves using external grade PVC construction adhesive.

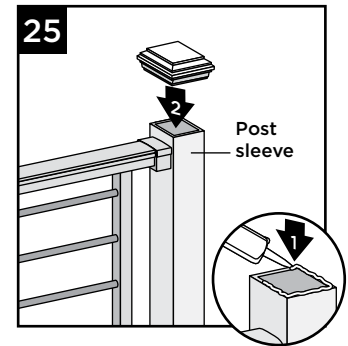

## HOW TO INSTALL TREX® SIGNATURE™ STAIR POSTS AND STAIR RAILING TREX® SIGNATURE™ STANDARD

### TOOLS NEEDED

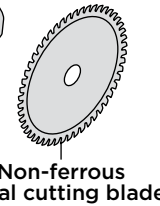
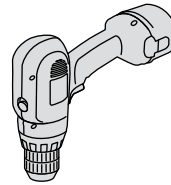
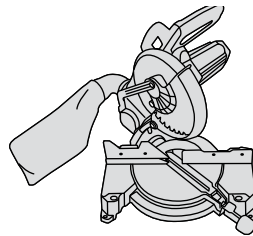
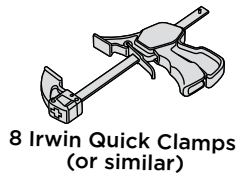
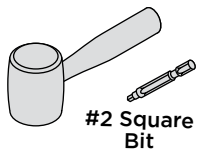

## INSTALLING STANDARD STAIR POSTS, OR PRESSURE-TREATED POST, POST SLEEVES AND SKIRTS TREX® SIGNATURE™ STANDARD

1. Make sure 53" (135.6 cm) posts are used for all stair posts.

2. If Trex® Signature™ stair posts are used, install at nose of stair tread directly under required blocking. Refer to Trex® Signature™ Instructions for detailed post installation.

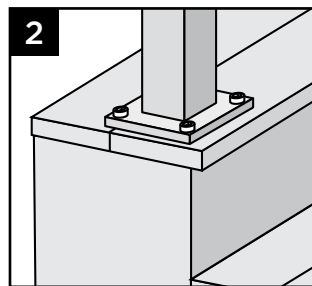

3. If pressure-treated post/post sleeves are used, posts are to be installed to the inside of the last stair stringer. (Rails must be over decking surface.) Refer to Trex® Signature™ Instructions for detailed post installation.

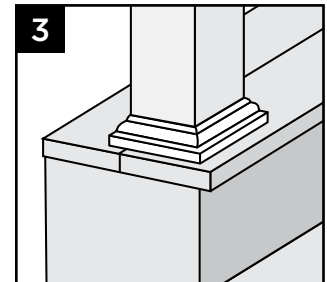

## BRACKET HARDWARE - STAIR APPLICATIONS TREX® SIGNATURE™ STANDARD

- AA. Bottom Stair Bracket and Cover - Lower Rail
- BB. Top Stair Bracket and Cover - Lower Rail
- CC. Fastener Pack
- DD. Bottom Stair Bracket and Cover - Upper Rail
- EE. Top Stair Bracket and Cover - Upper Rail

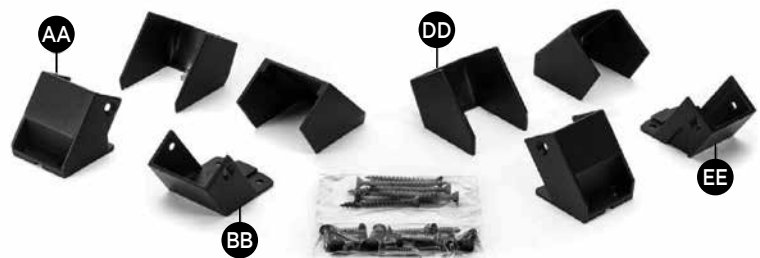



## HOW TO INSTALL TREX® SIGNATURE™ STAIR POSTS AND STAIR RAILING TREX® SIGNATURE™ STANDARD

### NOTES:

- » All Trex® Signature™ fixed stair brackets ONLY work with stair slopes of 32°-37°.
- » Illustrations shown are representations when using Trex® Signature™ post, but same rules apply if using pressure-treated posts and post sleeves.

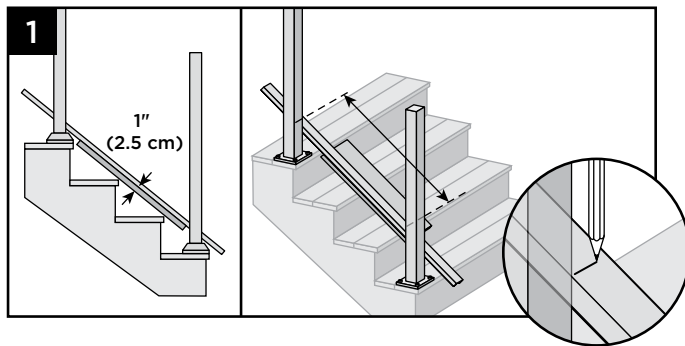

1. Place a 1" deckboard on the nose of the stair tread, then lay the bottom stair rail on top of the deckboard. Use the lower and upper stair post to set the size of the lower stair rail.

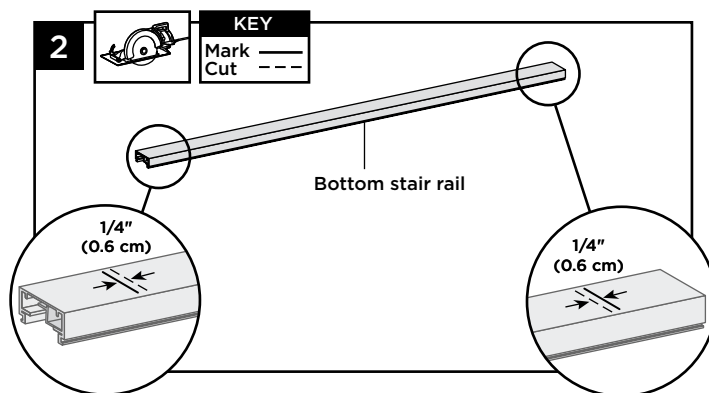

2. Cut each end of the bottom stair rail 1/4" (0.6 cm) shorter than the mark on each end to allow for fit into bottom stair rail brackets.

**NOTE:** Railing does not need to be cut at angle. Brackets are designed to allow for railing to be installed with standard straight cut.

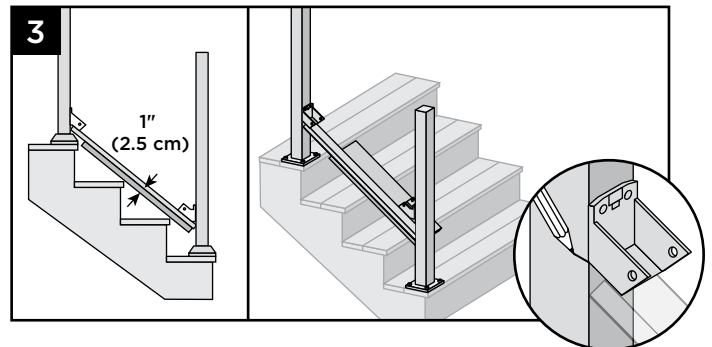

3. With deckboard still on nose of stair tread, place brackets on end of bottom stair rail (do not attach brackets to rail) and mark posts for bracket locations.

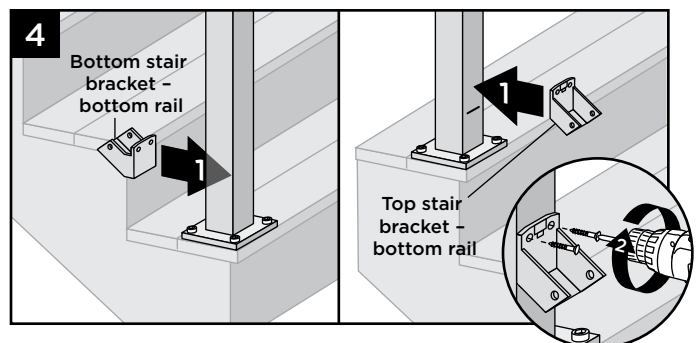

### Installing Lower Stair Brackets

4. Center lower stair bracket on post above the marked line and attach using two self-tapping screws (*provided*). In some cases it may be difficult to attach the stair bracket on the lower stair post. Recommend using a 90° drill adapter or loosen the post to get access to the lower bracket screw holes.

## Installing Upper Stair Brackets

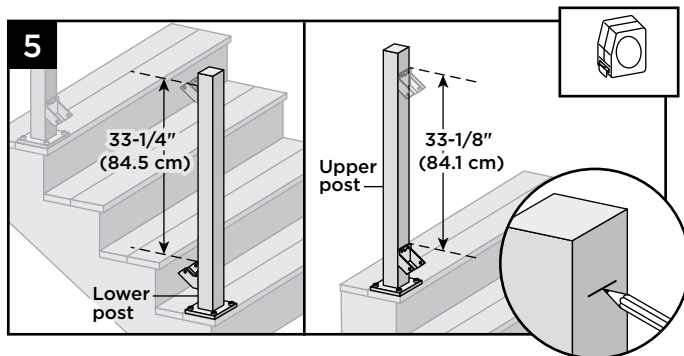

5. On Lower Post – From top of lower bracket, measure up and mark with light line 33-1/4".  
On Upper Post – From top of lower (upper) bracket, measure up and mark with light line 33-1/8".

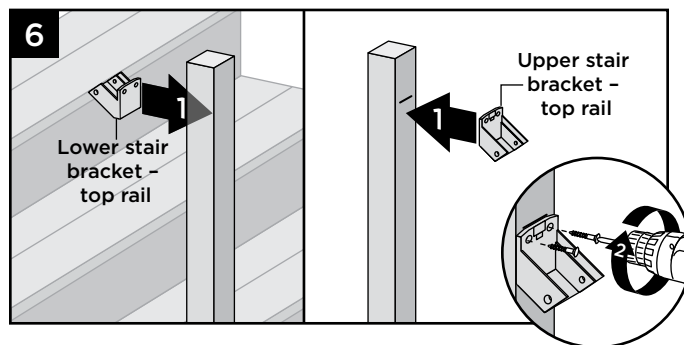

6. Center upper stair brackets on posts **below** the marked lines and attach using two self-tapping screws (provided).

7. Set bottom stair rail into bottom stair rail brackets.

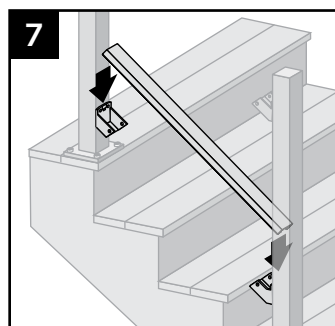

## How to Measure, Cut and Place Top Stair Railing

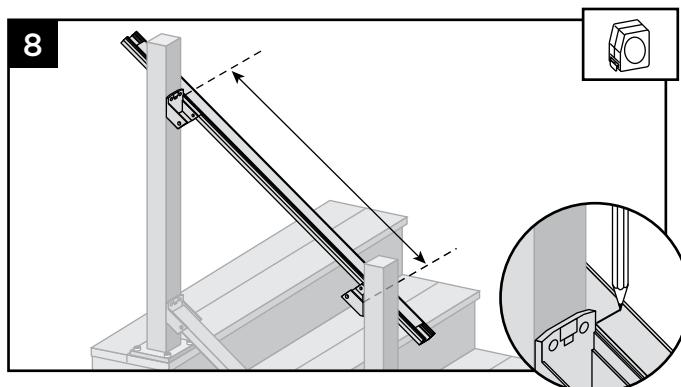

8. Position top rail to side of post. Mark top stair rail at each intersection.

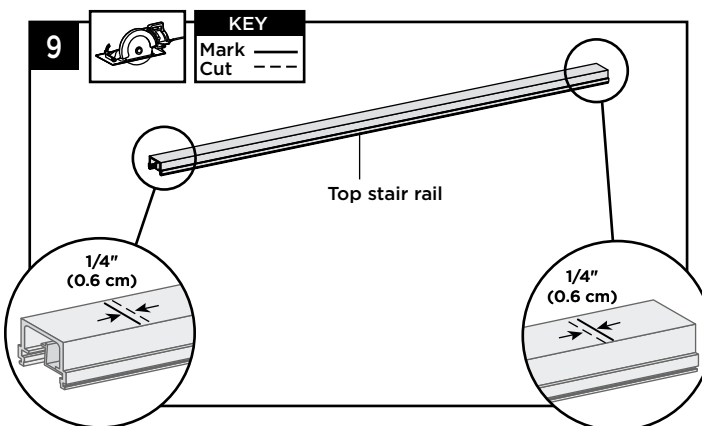

9. Cut each end of top stair rail along with rail insert 1/4" (0.6 cm) shorter than mark to allow for fit into top stair rail bracket.

**NOTE:** Railing does not need to be cut at angle. Brackets are designed to allow for railing to be installed with standard straight cut.

10. Set top stair rail into top stair rail brackets.

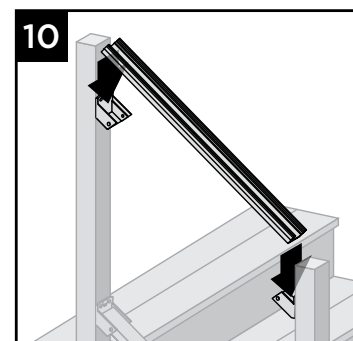



## Measuring and Cutting Rods

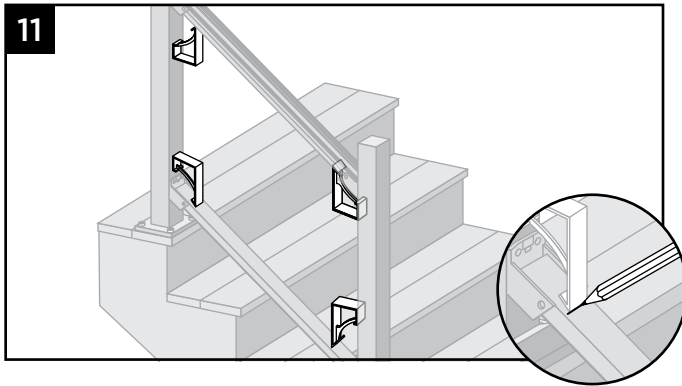

11. Using the long edge of the stair template, mark the location of the end verticals on the upper and lower rails.

**NOTE: Mark should only be 1" max length or it will be visible after installation of vertical.**

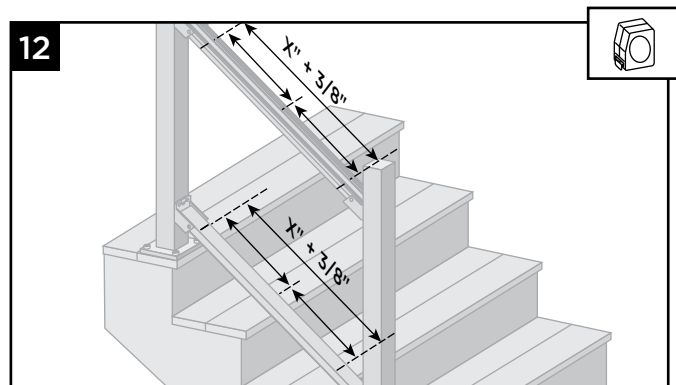

12. Measure and mark the mid-line (6' sections) of the two end marks of the top and bottom rail. Take that measurement and add 3/8" for rod length in next step.

**NOTE: For 8' sections divide the distance into thirds and make two marks for the two verticals.**

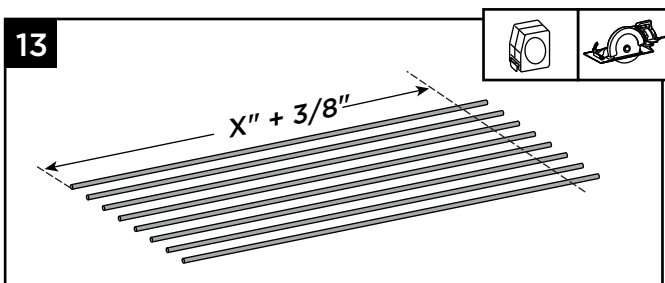

13. Cut rods to the length measured in previous step.

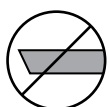

**IMPORTANT: DO NOT CUT RODS AT RAIL ANGLE; MAKE 90° CUTS ONLY!**

## Measuring and Cutting Verticals

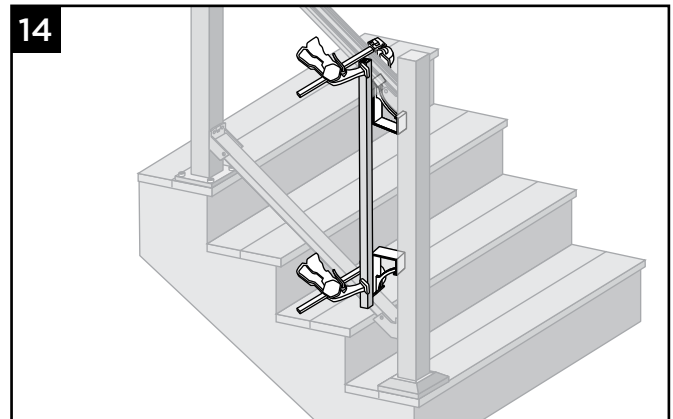

14. Clamp first vertical (lower part of stairs) in place, using width of stair template to position.

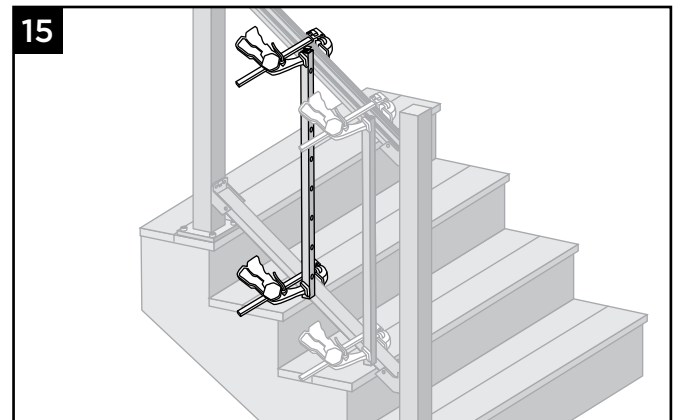

15. Clamp middle vertical(s) in place.

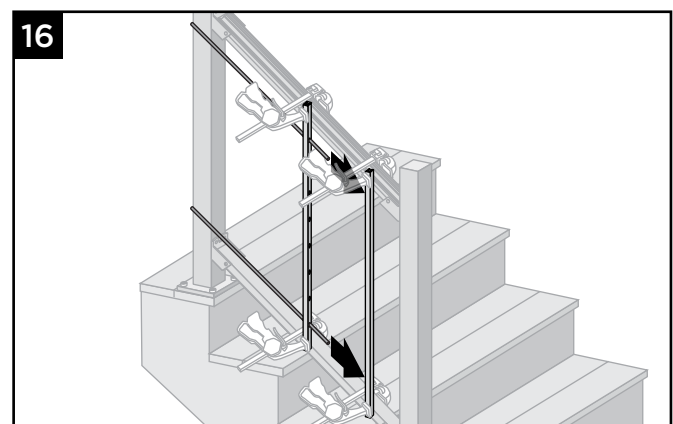

16. Slide a rod into top and bottom of all verticals. Ensure that distance of top rod to top rail and bottom rod to bottom rail are equal.

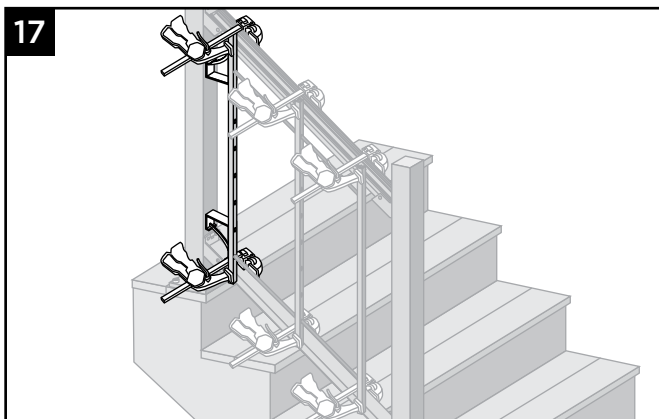

17. Clamp top vertical (upper part of stairs) in place, using width of stair template to position.

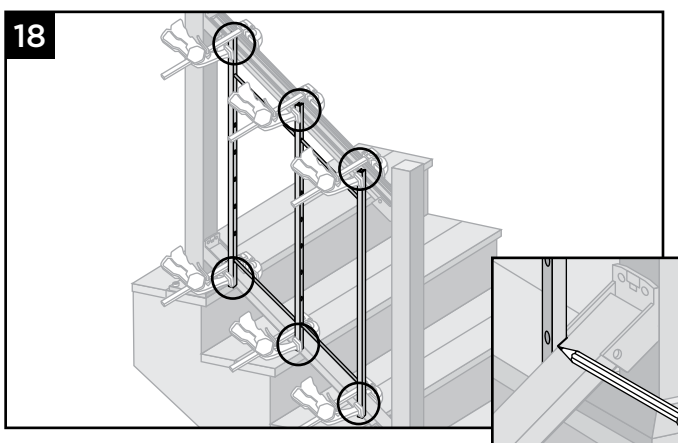

18. Mark angle cuts at top and bottom on all verticals

19. After removing rods and verticals, make angle cuts on top and bottom of verticals following marks from previous step.

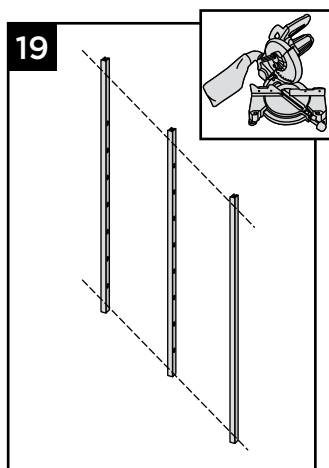

**Vertical and Rod Assembly**

20. Insert anti-rattle strips into the vertical supports.

**NOTE:** There are two anti-rattle strips for each support and can only be inserted in one side.

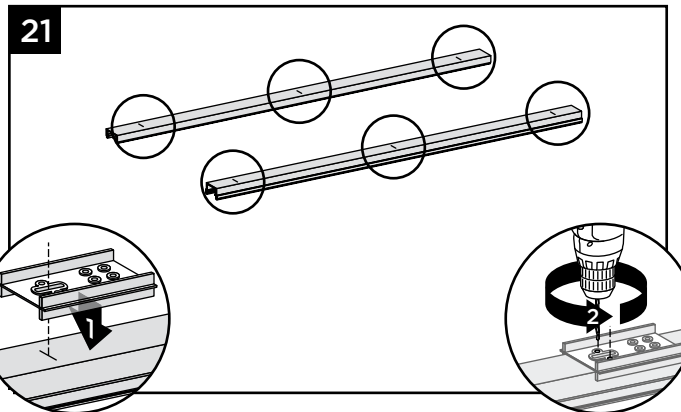
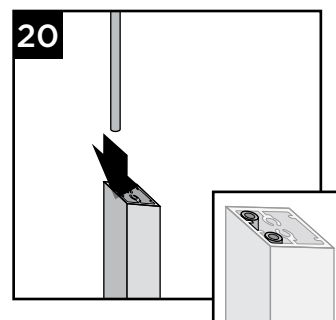

21. Using the slot on the HZ template, locate marked line and drill two 7/64" pilot holes at each mark (or mark with a punch).

**NOTE:** Pilot holes will be drilled out larger in next step.

22. Using pilot holes (or marks), drill 5/16" holes for all vertical supports in both top and bottom rails.

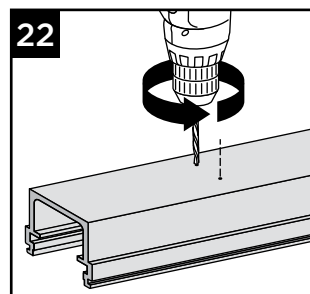

## Installing Top and Bottom Rails

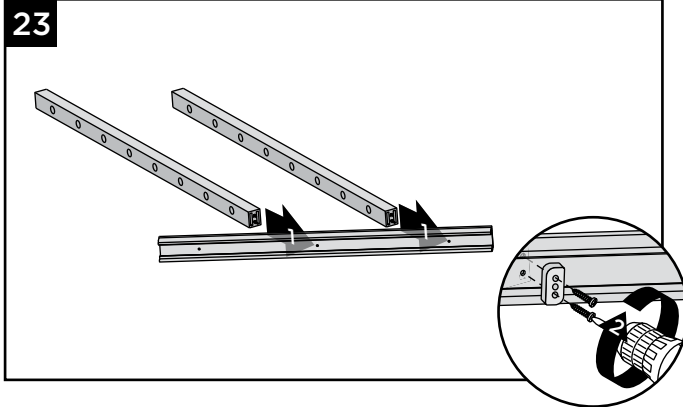

23. Install lowest end vertical and all intermediate verticals to bottom rail using ST Wedge Spacer and screws provided.

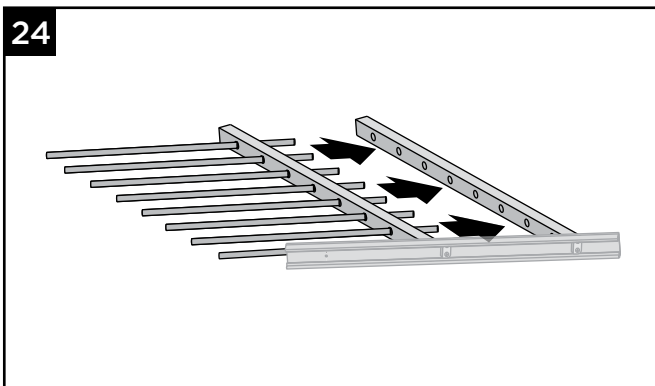

24. Slide rods into lower end and all intermediate verticals.

**NOTE:** When Inserting rods Into intermediate supports, keep rods straight to avoid scratching.

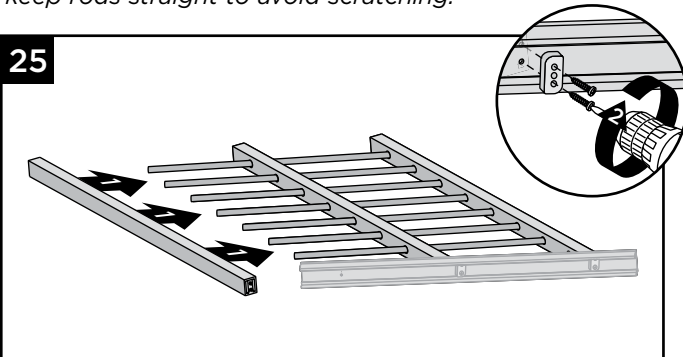

25. Slide upper end vertical onto rods and attach to bottom rail using ST Wedge Spacer and screws provided.

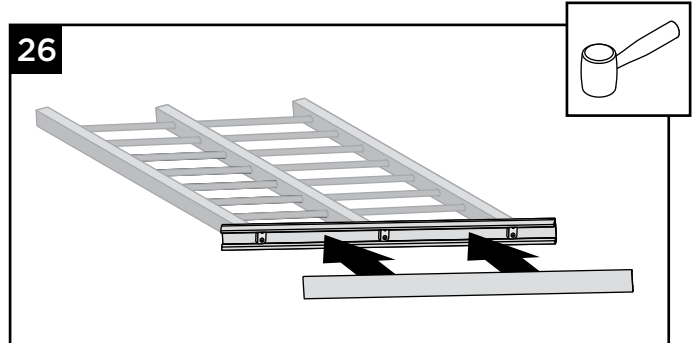

26. Using a mallet, install bottom rail cover onto bottom rail.

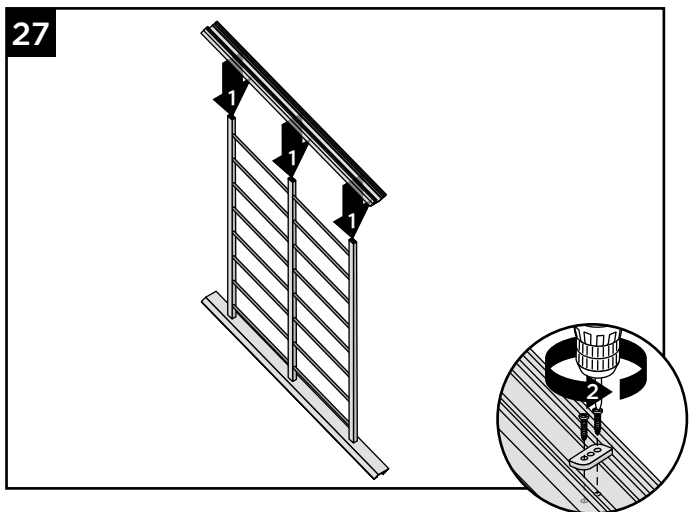

27. Install top rail to all vertical and end supports using ST Wedge Spacer and screws provided.

## Final Installation

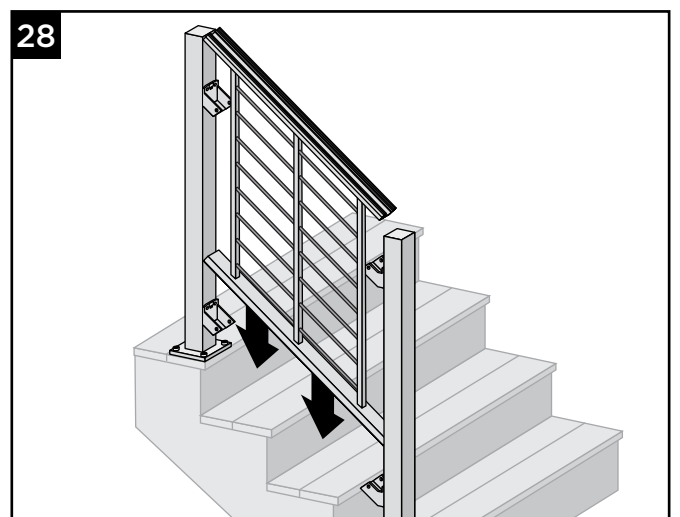

28. Drop assembled stair rod rail panel into brackets.

29. Attach bottom stair rail to bottom stair bracket using two self-tapping screws (provided) on each side of bracket.

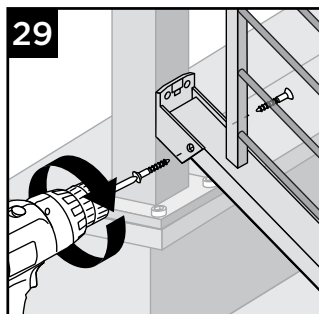

30. Attach top stair rail to top stair bracket (all types) using two self-tapping screws (provided) on each side of stair bracket.

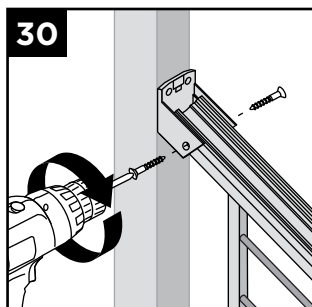

### Attachment of Bracket Covers, Skirts, and Caps

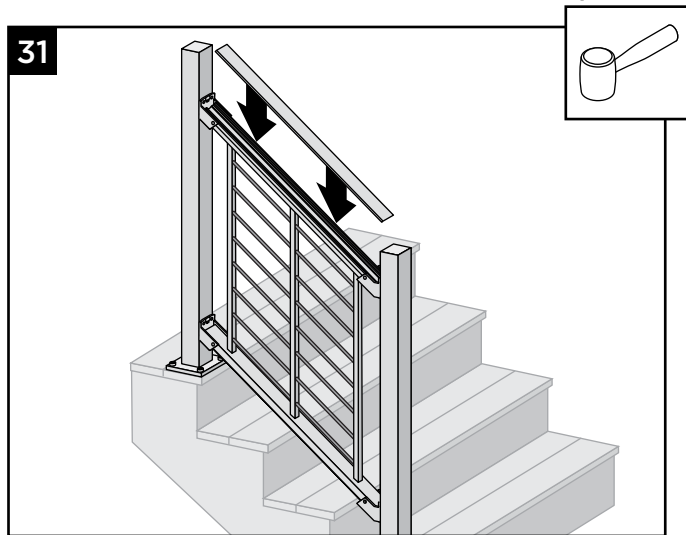

31. Using a mallet, install top rail cover.

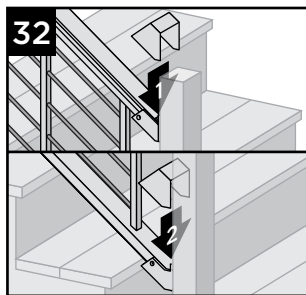

32. Attach corresponding bracket covers over opening in upper and bottom rails.

33. Attach provided post skirt to bottom of posts when using Trex® Signature™ posts.

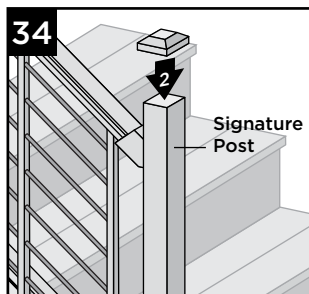
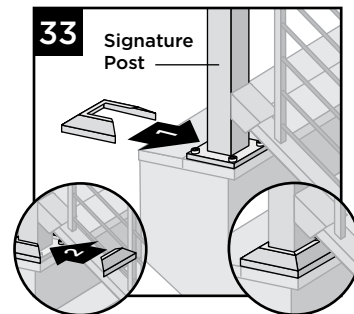

34. Attach post caps to Trex® Signature™ posts. (Use of **rubber mallet** may be required for secure attachment.)

35. Attach post caps to post sleeves using external grade PVC construction adhesive.

